

Available through:
POWER PLANT SUPPLY CO
www.powerplantsupplyco.com

ONTARIO, CANADA
sales@powerplantsupplyco.com
Toronto, ON 416 752 3339
ATLANTIC, CANADA:
Halifax, NS: 902 435 9899
atlantic@powerplantsupplyco.com
St John's: NL 709 747 7670
nl@powerplantsupplyco.com



It's hot!



The Riser-Wrap™ seal is a two-layer system designed for corrosion and sealing protection on pipelines and encapsulating manholes to seal joints against ground water infiltration.

The first layer is a visco-elastic adhesive liquid sealant covered by a heat shrink sleeve. The heat shrink is a thick-walled .098" (2.5mm), cross-linked, high density polyethylene membrane.

Applications:

- Manhole Encapsulation/Sealing
- Pipelines
- Repair and Rehabilitation
- Step-Down Joints
- Square/Rectangular Vaults



Riser-Wrap™ Square Vault Application

Riser-Wrap Sealing System Features and Benefits:

Low Preheat Requirements

- Preheat required only to remove the moisture from the surface and for fast/easy installation.

Offers Permanent Heat Change Indicators

- Permanent Heat Indicator ensures that the correct application of heat has been applied to the entire heat shrink sleeve.
- Installation is fully inspectable at any time after the installation.

High Modulus of Elasticity Backing

- Accommodates ground movement.

High Impact and Penetration Resistance

- Toughness to resist soil stress.

High Shrink Force

- Optimizes flow and fill of visco-elastic adhesive sealant.
- Seals against ground water infiltration.

Impermeable

- Provides corrosion protection.
- Extends structure life.

No Special Tools

- Quick & easy installation.

Riser-Wrap Sealing System Properties:	ASTM Test	TEST RESULTS	
Adhesive			
Softening Point	ASTM E-28	205°C	400°F
Lap Shear	ASTM D-1002	12N/cm ²	18psi
Backing			
Tensile Strength	ASTM D-638	22mPa	3,300psi
Elongation	ASTM D-638	650%	
Hardness, Shore D	ASTM D-224	58 Shore D	
Shrink Force	ASTM D-638	26N/cm ²	38psi
Dielectric Strength	ASTM D-149	20KV/mm	500KV/in.
Sleeve			
Peel Strength	ASTM D 1000	20N/cm	11lb/in.
Water Absorption	ASTM D-570	0.05%	
Low Temp. Flexibility	ASTM D-2671	-40°C	-40°F
Penetration Resistance	ASTM G-17	PASS	

Riser-Wrap™ Heat Shrink System - Typical Specification

1.0 Scope

Apply PSI Riser-Wrap™ heat shrinkable sleeve on exterior concrete manholes or other structures at locations indicated by the Engineer to protect manhole and reduce infiltration or ingress of water and other contaminants. The sleeve shall be applied over a cleaned, primed surface. The Riser-Wrap™ system shall be as manufactured by Pipeline Seal & Insulator, Inc, Houston, Texas

2.0 Sleeve - High Density Polyethylene Membrane.

The heat shrinkable sleeve shall consist of an 11" or 17" wide wrap-around, 2.5mm thick, cross-linked high density polyethylene membrane complete with a mastic. Peel Strength shall be a minimum of 11 lb./in. per ASTM D 1000. Tensile Strength shall be 3,300 psi minimum per ASTM D-638. Mastic softening point shall meet or exceed 400°F in accordance with ASTM E-28. Sleeve shall incorporate permanent heat indicators, to assure proper heating.

3.0 Joiner-Strip

The material to close the sleeve shall consist of a high density polyethylene fiber reinforced material to assure sleeve pulls tight. Lap Shear on assembled system shall exceed 18psi per ASTM D-1002.

4.0 Primer

Primer shall be a Polyken 1027 or 1039 primer. Primer shall be black in color and applied at a rate of approximately 2 – 3 mills. Must be able to dry with-in one hour.





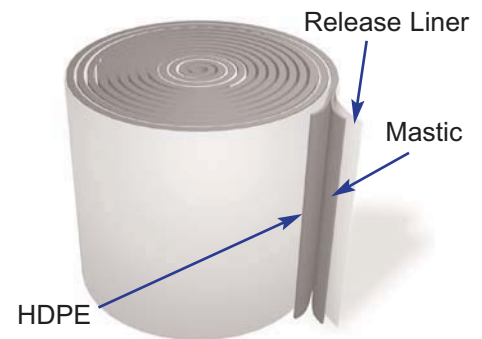





Riser-Wrap™ Vacuum Test

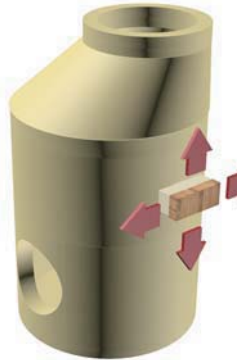

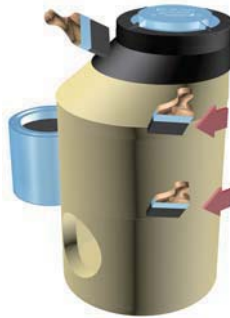
Available in 17", 11" and 5.5" widths x 50 ft. rolls.

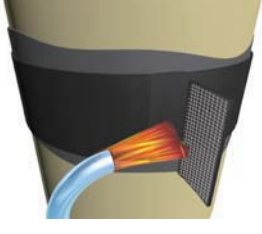

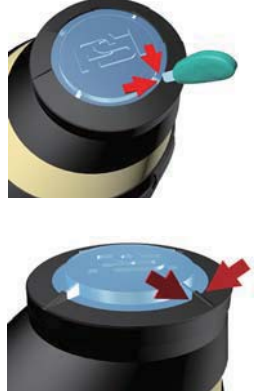
Basic Installation Guidelines

 <p>1. Clean all exterior surfaces of the manhole with a brush or broom to remove any loose cement, dust or small rock particles.</p>	 <p>2. Preheat manhole surface. The function of preheating is to remove excess moisture.</p>	 <p>3. Apply Polyken #1027 or #1039 liquid adhesive primers to the entire exposed concrete application surface.</p>	 <p>4. Remove 8" (20cm) of release backing and position exposed surface on cleaned and primed seam area. Expose 8" (20cm) sections at a time as you wrap the sleeve material around the entire circumference of the manhole.</p>	 <p>5. Using a small amount of flame, heat the adhesive side (Fiber Reinforced) of the adhesive joiner-strip. Center the strip vertically over the overlap sleeve edge, hold in place and apply small amount of heat to the face of the joiner-strip (Black Side).</p>
 <p>6. Using a moderate to high flame, begin heating Riser-Wrap™ sleeve material from the bottom edge moving around the structure in one direction.</p>	 <p>7. Carefully cut the Riser-Wrap™ sleeve when applying over cast iron manhole gussets. Gently mold with heat the sleeve around gussets with roller/gloved hand.</p>	<p>8. Inspection Visually inspect the installed sleeve to make sure the sleeve is in full contact with the cone section and manhole frame. Also verify that the adhesive flows beyond the sleeve edges and that no cracks or holes exist in the sleeve backing.</p>	<p>9. Backfilling Guidelines After shrinking is complete, allow the sleeve to cool prior to backfilling. Water quenching of the sleeve is acceptable to facilitate immediate backfilling. To prevent damage to the sleeve, use selected backfill material (no sharp stones or large particles) otherwise an extruded polyethylene mesh or other suitable shield should be used.</p>	<p>Optional: Gusset Installation Use small sections (4" to 6" strips) of filler cord and mold around gussets.</p> 

Primer Not Needed for Asphalt or Bituminous Coated Concrete.
Apply Riser-Wrap directly on the coated surface. Do not apply Polyken 1027 or 1039 primer over asphalt. Apply primer to bare surfaces only.

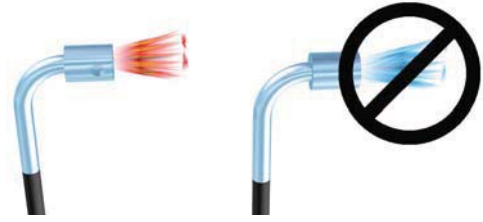

Use yellow/orange flame when heating RW material. Blue flame will overheat material.

Note: Detailed/Complete Installation Guidelines packaged with boxed Riser-Wrap™ material.



- Tools Required for Installation**
1. Approved torch assembly, regulator and Propane bottle. (BN-80 head suggested)
 2. Tape Measure. (16')
 3. Heavy Duty Knife.

4. Paint Brush or Paint Roller.
5. Marking Pens. (Sharpie)
6. Heat Resistant Gloves or Welder's Gloves.
7. Approved surface rolling device. (4" roller)
8. Wire brush or broom.
9. Approved solvent or cleaner & rags.
10. Crescent Wrench
11. Safety Glasses or Goggles

Ordering:

Riser-Wrap heat shrink sleeves can be supplied in 5.5" (140mm), 11" (280mm) or 17" (432mm) widths and shipped in 50 ft. rolls. Primer and joiner-strips required.

To determine the amount of RW material required:

Sleeve Width: Measure width of area to cover. Add about 3" above and below seal area.

Select 17", 11" or 5.5" widths.

Note: Select sleeve width that will overlap by 2" (50mm) on each side of the overlap joint. Figure 10% shrinkage during installation of sleeve width when calculating the minimum sleeve width.

Sleeve Length: Measure **Circumference** of pipes, cones, manhole frames/rings, concrete risers at the widest or largest point. {When measuring use the following formula}.

Circumference + 6" = RW Length

Example: **18" Dia. Grade Ring**
Circumference = 56.52 - Round up to 57"
57" + 6" = 63"

USE: **RW 17" x 63" Sleeve**

To determine the number of primer cans required.

Primer is supplied in 1 gallon cans, which covers 320 sq. ft. @ 2-3 mils brushed or rolled.

Example: $\frac{63" (\text{Length}) \times 17" (\text{Width})}{144" / \text{sq. ft.}} = 7.4 \text{ sq. ft.}$

To determine the amount of RW Joiner-Strips.

Order in 5.5", 11" or 17" for each RW application.

1-RW-JS-17"

Storage & Safety Guidelines

To ensure maximum performance, store products in a dry, ventilated area. Keep products sealed in original cartons and avoid exposure to direct sunlight, rain, snow, dust or other adverse environmental elements. Avoid prolonged storage at temperatures above 130°F. (54°C.) or below -4°F. (-20°C.). Product installation should be done in accordance with local health and safety regulations.



Riser-Wrap™ 11" Material

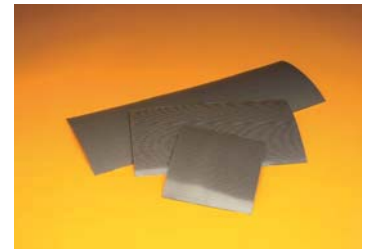

Joiner-Strips



Polyken Primer

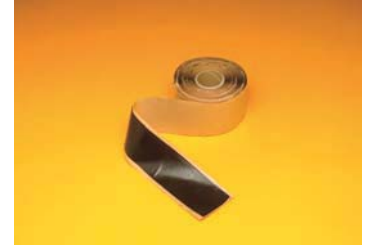

Filler Cord

Warranty:

All products are warranted against failure caused by manufacturing defects for a period of one year. Any product found to be so defective and returned within one year from date of shipment will be replaced without charge. The above warranty is made in lieu of, and we disclaim, any and all other warranties, expressed or implied, including the warranties of merchantability and fitness for a particular purpose, and buyer agrees to accept the products without any such warranties. We hereby disclaim any obligation or liability for consequential damages, labor costs or any other claims or liabilities of any kind whatsoever.

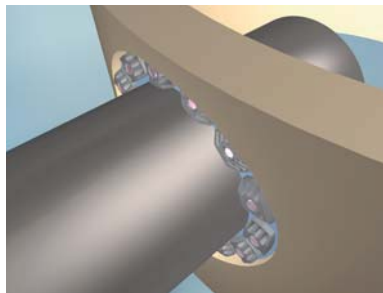

The Complete Manhole Sealing System

Link-Seal® Modular Seals in Combination with Riser-Wrap heat shrink sleeves.

Create a Positive Hydrostatic Seal (20 psig, 40 feet head) in the annular space between Pipe and Pre-Cast Base. See Link-Seal Engineering Manual for Link-Seal modular seal selection when sealing pipe penetrating curved concrete surfaces.

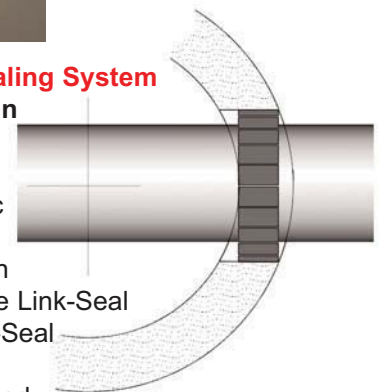

Riser-Wrap™ used to rehab. an existing manhole submerged in runoff water.



Manhole, Concrete tanks, concrete pipe, joints, Joint shrink seals, Manhole Joint seal tapes; Power Plant Supply Co has convenient shipping warehouse locations in Canada, to serve customers in Ontario, ON, Quebec, QC, Atlantic Canada, including New Brunswick, NB, PEI, Nova Scotia, NS, Newfoundland & Labrador, NL, British Columbia, BC, Alberta, AB, Manitoba, Man, Saskatchewan, SK, Nunavut, Northwest Territories, NWT, Yukon. Next day Air or convenient ground to major cities including Vancouver, Calgary, Edmonton, Fort McMurray, Winnipeg, Yellowknife, Thunder Bay, Hamilton, Toronto, Ottawa, Montreal, Quebec City, Saint John, Moncton, Fredericton, Charlottetown, Halifax, Sydney, Corner Brook, St John's

<mailto:sales@powerplantsupplyco.com>